

HILTI

D-LP 15/ DS-TS 22

Operating instructions

en



D-LP15 / DS-TS22

- ① D-LP15 hydraulic unit
- ② D-RC 22 remote control unit
- ③ DS-RF rail support
- ④ D-R 200 L rail (length 200 cm)
- ⑤ DS-ES-L end stop
- ⑥ DS-TS 22 saw head
- ⑦ DS-B saw blade
- ⑧ DS-BG blade guard
- ⑨ D-PH 58-10 $\frac{5}{8}$ " hydraulic hoses
- ⑩ D-FH 4/14-10 $\frac{1}{4}$ " hydraulic control hoses
- ⑪ Water supply hose



1. General information	4
2. Safety precautions	5
3. The D-LP 15 / DS-TS 22 modular hydraulic saw system	11
4. General description and technical data D-LP 15 / DS-TS 22	12
5. Spindle speeds, gear selection, rules of thumb, sawing procedure, saw blades	13
6. Preparing the workplace and saw system	14
7. Setting up the saw system for various applications	15
8. D-LP 15 hydraulic unit – setting up, operation, care and maintenance	22
9. Setting up, checking and operating the hydraulic saw system	23
10. Disassembly and fault finding	25
11. Care and maintenance	27
12. Manufacturer's warranty – tools	28
13. EU declaration of conformity (original)	29

1. General information

1.1 Safety notices and their meaning

The operating instructions must be read carefully before the equipment is put into operation. Always keep these operating instructions with the equipment. The wire saw system should be handed over to other persons only complete with the operating instructions.

DANGER

Draws attention to imminent danger that will lead to serious bodily injury or fatality.

WARNING

Draws attention to a potentially dangerous situation that could lead to serious personal injury or fatality.

CAUTION

Draws attention to a potentially dangerous situation that could lead to slight personal injury or damage to the equipment or other property.

NOTE

Draws attention to an instruction or other useful information.

1.2 Explanation of the pictograms and other information

Warning signs



General warning



Warning: electricity



Warning: avoid hand injuries



Warning: Risk of cutting injury

Obligation signs



Wear eye protection.



Wear a hard hat.



Wear protective gloves.



Wear safety footwear.



Wear respiratory protection.



Wear ear protection.

Symbols



Read the operating instructions before use.

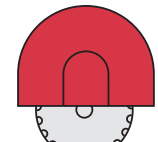

Always fit the blade guard



Always fit the rail end stops

A

Amps

V

Volts



Alternating current

Hz

Hertz

n_0

Nominal speed under no load



Diameter

mm

Millimeters

/min

Revolutions per minute

rpm

Revolutions per minute

Safety precautions		
2.1	General safety information	6
2.2	Use of the equipment as directed	7
2.3	Electrical safety precautions	7
2.4	Safety precautions during transport	7
2.5	Safety measures at the working area	8
2.6	Preparations	8
2.7	Safety precautions to be observed when assembling, securing and operating the wall saw	9
2.8	Securing the objects being cut and disposal of sawing slurry	10

2. Safety precautions



2.1 General safety information

■ Sawing work influences the statics of the structure. Approval must be obtained from the site engineer or architect prior to carrying out drilling and sawing work.

■ You must be fully aware that working with the D-LP 15/DS-TS 22 hydraulic saw system always involves a certain element of risk due to wear or damage to parts. Check the condition of the entire system, including accessories, each time before use to ensure it functions correctly.

Wearing parts such as the blade guard holder rubber, end stop, blade mounting screw, flush-cutting blade mounting screws, etc., should be inspected particularly carefully. Check that all parts have been assembled correctly and consider all other factors that could influence operation of the equipment.

Contact your Hilti representative or Hilti service centre if faults or deficiencies are found.

■ Use the hydraulic saw system only when you have read the operating instructions, when you are familiar with the information contained therein and when you have been trained to use the equipment safely by a Hilti specialist. All warnings and safety information must be observed.

■ The area in front of, behind or below the surface where sawing work or drilling work is to be carried out must be secured in such a way that persons or equipment cannot be injured or damaged by falling objects. If necessary, concrete cores or blocks of concrete that have been cut free should be secured to prevent them falling.

■ The operator in charge must be aware of the possible dangers and of his responsibility for safety, both with regard to himself and to others.



■ Read the operating instructions carefully before operating the equipment for the first time and observe all precautions and instructions contained therein.

■ The influences of the environment in which you are working must be taken into account. Do not position the equipment where the hydraulic unit is liable

to become very wet. The hydraulic unit must be kept level during operation, i.e. on a horizontal surface. Secure the hydraulic unit at locations where there may be a risk of it falling (e.g. on scaffolding). The electric extension cable and its plugs and sockets must not be allowed to lie in water. Do not use the equipment in the vicinity of inflammable liquids or gases. Make provision for water removal and disposal.

■ Always keep the operating instructions with the equipment and pass them on to any subsequent user who has been trained in its use.

■ When not in use, store the hydraulic saw system in a locked, dry place out of reach of children.

■ Use the hydraulic saw system only for the applications for which it has been designed.

■ In addition to carrying out the specified care and maintenance, careful cleaning is also a prerequisite for safe, trouble-free operation of the equipment.

■ Always stay alert and carefully observe the progress of your work. Proceed logically and do not use the equipment when you are unable to concentrate on your work.

■ Do not leave tools (e.g. open-end wrenches) in place on the equipment. Check the drive unit to ensure that all tools have been removed before switching on.

■ Keep the working area tidy and well lit. An untidy workplace and inadequate lighting increases the risk of accident.



■ Wear suitable, close-fitting work clothes including a hard hat, protective goggles, protective gloves, safety footwear, ear protectors and a hair net, if you have long hair.



■ Respiratory protection should be worn when working in enclosed or poorly ventilated areas and when dry cutting is being carried out.

■ Keep children and other persons well away from the workplace and allow no-one to touch the wall saw or power cable.

■ **Failure to comply with the warnings and safety information may lead to severe or possibly fatal injury as well as serious damage to the equipment and other property.**

■ **Before beginning work, check the working area (e.g. using a metal detector) to ensure that no concealed electric cables or gas and water pipes are present.** External metal parts of the machine may become live, for example, when an electric cable is damaged accidentally. This presents a serious risk of electric shock.

■ **The machine is not intended for use by children, by debilitated persons or those who have received no instruction or training.**

■ **Children must be instructed not to play with the machine.**

■ Dust from material such as paint containing lead, some wood species, minerals and metal may be harmful. Contact with or inhalation of the dust may cause allergic reactions and/or respiratory diseases to the operator or bystanders.

Certain kinds of dust are classified as carcinogenic such as oak and beech dust especially in conjunction with additives for wood conditioning (chromate, wood preservative). Material containing asbestos must only be treated by specialists.

Where the use of a dust extraction device is possible it shall be used. To achieve a high level of dust collection, use a suitable vacuum cleaner of the type recommended by Hilti for wood dust and/or mineral dust together with this tool. Ensure that the workplace is well ventilated. The use of a dust mask of filter class P2 is recommended. Follow national requirements for the materials you want to work with.

2.2 Use of the equipment as directed

■ The D-LP 15/DS-TS 22 hydraulic saw system has been developed for the technical demolition of steel, concrete, stone or brickwork structures in construction and civil engineering applications. It can be used for wet or dry sawing (the wet sawing technique is normally used). Use extending beyond this is considered to be not as directed and requires to be clarified in advance with the manufacturer.

■ The hydraulic saw system may be operated only by specialists trained in concrete cutting techniques, referred to in the following as “operators”. These persons must be familiar with the content of these operating instructions and must have been trained in their safe application by a Hilti specialist.

■ National regulations and laws, as well as the oper-

ating instructions and the safety information applicable to the accessories employed (saw blade, fastening accessories etc.) must be observed.

■ Use only the accessories recommended in these operating instructions. The use of other accessories may result in damage or injury. Use only original Hilti spare parts.

■ Use only saw blades approved for a cutting speed of 63 m/sec.



2.3 Electrical safety precautions

■ Connect the unit only to a power source equipped with an earth conductor and ground fault circuit breaker (PRCD). Check that these items are in perfect working order before operating the equipment.

■ Make sure that the mains voltage corresponds to the specification given on the rating plate.

■ Protect yourself against electric shock, i.e. avoid contact with earthed components such as pipes, radiators and the like.

■ Check the condition of all cables and plugs each time before use.

■ Keep all electric cables, especially their plug connections, in a dry condition. Close the electric sockets by means of the covers supplied when not in use.

■ Use of extension cables: Use only extension cables with adequate conductor cross-section which are approved for the intended field of use. Do not work with extension cables when they are rolled up. This can result in a drop in output at the equipment and may cause the cable to overheat. Replace damaged extension cables.

■ Disconnect the power cable before beginning cleaning and maintenance work or in the event of a lengthy interruption between periods of operation.

■ Any generator used must be earthed when in operation.



2.4 Safety precautions during transport

■ Make sure that the hydraulic saw system cannot move about during transportation.

2. Safety precautions

- Always avoid adopting a bent-over body position when carrying heavy items, i.e. keep your back straight when lifting and carrying. Maintain a secure stance, especially when using ladders or when working from scaffolding.
- Use the handles provided for transportation of the drive unit and control unit. Ensure that the handles are always kept clean and free of grease.
- If the drive unit and control unit are to be transported by means of a crane, the lifting points provided must be used.
- Only suitable, conventional site cranes or mobile cranes may be used for lifting.

2.5 Safety measures at the danger areas

- Safety measures must be implemented in the area where sawing is taking place to ensure that operators and bystanders cannot be injured or property damaged by debris that may fly off or fall down (broken-off diamond segments, small stones, sawing slurry, etc.) while sawing is in progress. Safety measures must also be implemented in the area not directly visible to the operator, i.e. behind where sawing is taking place.
- Persons must NEVER enter the danger area (3 meters in all directions from the line of the cut to be made) while the blade drive is switched on.

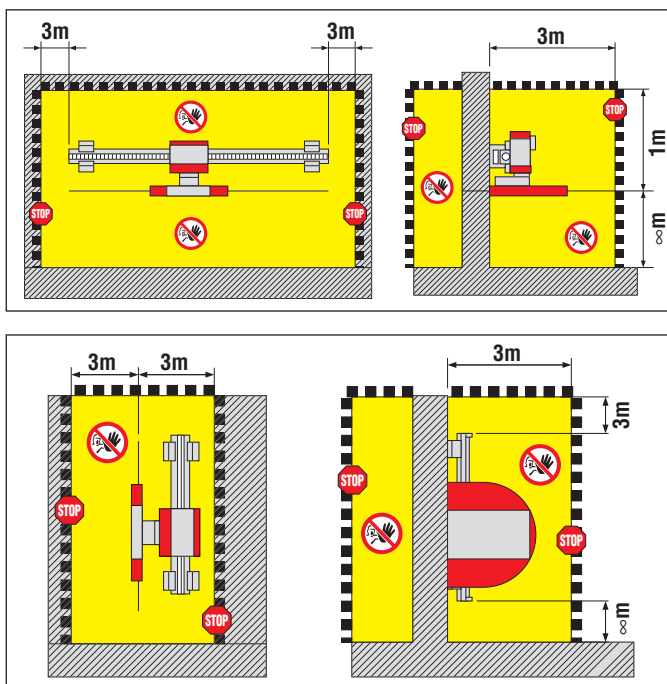

CAUTION

Secure the working area. Ensure that no persons can be injured or property / equipment damaged by falling objects or debris that may fly off during the sawing operation.

1. Approval must be obtained from the site engineer or site management before beginning the sawing work.
2. Find out whether overcutting at corners is permitted. If not, the corresponding corner holes must be planned and drilled first.
3. Check that the area is cordoned off, that supports are in place and warnings to third parties are displayed.

When setting up and operating the saw system and when removing parts that have been cut away, always ensure that no persons are below the area in which you are working. Falling objects could cause serious injury.

The danger area may be entered only when the machine is switched off at the main switch (emergency-off button pressed).



2.6 Preparations

- Keep the working area tidy and always unroll the full length of hoses and cables. Untidiness and bad organisation of the working area can lead to accidents.
- Make sure that no gas, water, electricity or other supply lines are located in the cutting area. Supply lines located close to the cutting area which could be damaged by falling parts, for instance, must be specially protected and, if necessary, temporarily switched off etc.
- Ensure that the cooling water used is drained or extracted in a suitably controlled manner. Water that is allowed to drain away or spray around in an uncontrolled manner can lead to damage or accidents. The fact that water could drain away into internal, hidden cavities, e.g. in brickwork or masonry, must also be taken into account.
- Make a careful note of any influence the immediate surroundings may have on operations. Do not use the hydraulic saw system in areas where there is a risk of

explosion or in close proximity to combustible materials, fluids or gases. Flying sparks or electrostatic discharge can lead to fires or explosions.

- Do not cut materials which may produce toxic or explosive dust or vapours when cut.
- Do not cut easily combustible aluminium or magnesium alloys.

2.7 Safety precautions to be observed when assembling, securing and operating the wall saw

WARNING

Use an anchor suitable for the material on which you are working and observe the anchor manufacturer's instructions.

NOTE

Hilti M12 metal expansion anchors are usually suitable for fastening diamond core drilling equipment to uncracked concrete. Under certain conditions it may be necessary to use an alternative fastening method. Please contact Hilti Technical Service if you have any questions about secure fastening.

- Use metal anchors (size M12) for fastening DS-RF rail supports and DS-RFP angular cutting plates. Secure fastenings of a type suitable for the material being cut must be installed, e.g. Hilti HKD-D, HSA-A, Hilti HIT, HEA / HAS anchors.
- Use only ISO 8.8 grade fastening screws for the rail supports.



- An end stop must always be fitted at the end of the rail to prevent unintentional advance beyond this point (prevents saw coming off the end of the rail).



- The blade guard must always be in place when the saw is in use. NEVER stand in the direction of radial flight of a running saw blade. Special precautions must be taken to secure the danger area when special cutting applications are in progress.
- Always operate the machine from the closed side of the blade guard when corner cuts are made with the

blade guard in the partly open position. The operator must take additional precautions (fit a cover, plank of wood, boards etc.) where necessary.

- Never attempt to connect or disconnect hydraulic hoses while the hydraulic unit is running and while the hoses are under pressure.



- Handle the DS-RFP angular cutting plate carefully. There is a risk of pinching your fingers.



- It is essential that the prescribed checks are carried out before beginning sawing (see section 9.1)



- Unless special safety precautions are taken, the D-LP 15/DS-TS 22 must NOT be operated in environments where there is a risk of explosion.
- The hydraulic unit and the operator with the remote control unit should be positioned as far as possible outside the danger zone. The operator with the remote control unit should remain at a safe location while the saw is in operation.
- Use only adequately dimensioned fastening materials to secure the saw (anchors, screws, etc.). Recommendations can be found in our catalogues and brochures.
- Operate the saw only when the blade guard and rail-end stops have been fitted and secured.
- Observe the recommended cutting speeds and advance pressures while sawing.
- Protective gloves should be worn as the oil and parts of the equipment can become very hot.
- Wear the protective clothing and other items of protective equipment listed in section 2.1.
- Before each cut, check that there is no play between the saw head and the rail and that the eccentric rollers are engaged.
- When additional safety precautions are taken, overhead sawing is also possible. In this case, the blade guard must be equipped with a means of water drainage. Do not stand beneath the saw.

2. Safety precautions



2.8 Securing the objects being cut and disposal of sawing slurry

- Steel wedges and/or supports must be used to prevent uncontrolled movement of parts being cut free in order to avoid injuries and to prevent the saw blade becoming trapped or jammed.
- Use only approved and appropriately dimensioned means of securing and lifting for the removal and transportation of parts that have been cut free. Such parts may have a weight of many tons.
- Never loiter in the vicinity of loads suspended by cranes.
- The point at which the cut is made and any resulting opening must be safely and visibly cordoned off to prevent persons falling and to exclude the risk of damage or injury.
- Introducing sawing slurry into the drains or sewage system without suitable pre-treatment is problematic from an environmental point of view. Ask the local authority responsible about existing regulations. We recommend the following pre-treatment:
 - Collect the sawing slurry (e.g. using an industrial vacuum cleaner)
 - Allow the slurry to settle and dispose of the solid portion of the waste at a building waste disposal location (the separation process can be accelerated by adding a flocculent).
 - Neutralise the residual water by adding a neutralising agent or dilute it by adding a large quantity of water before allowing it to enter the drainage system.
- Always switch off the hydraulic power unit before setting up or dismantling the saw or before carrying out any other manipulation of the saw head or blade, etc.

3. D-LP15/DS-TS22 modular hydraulic saw system

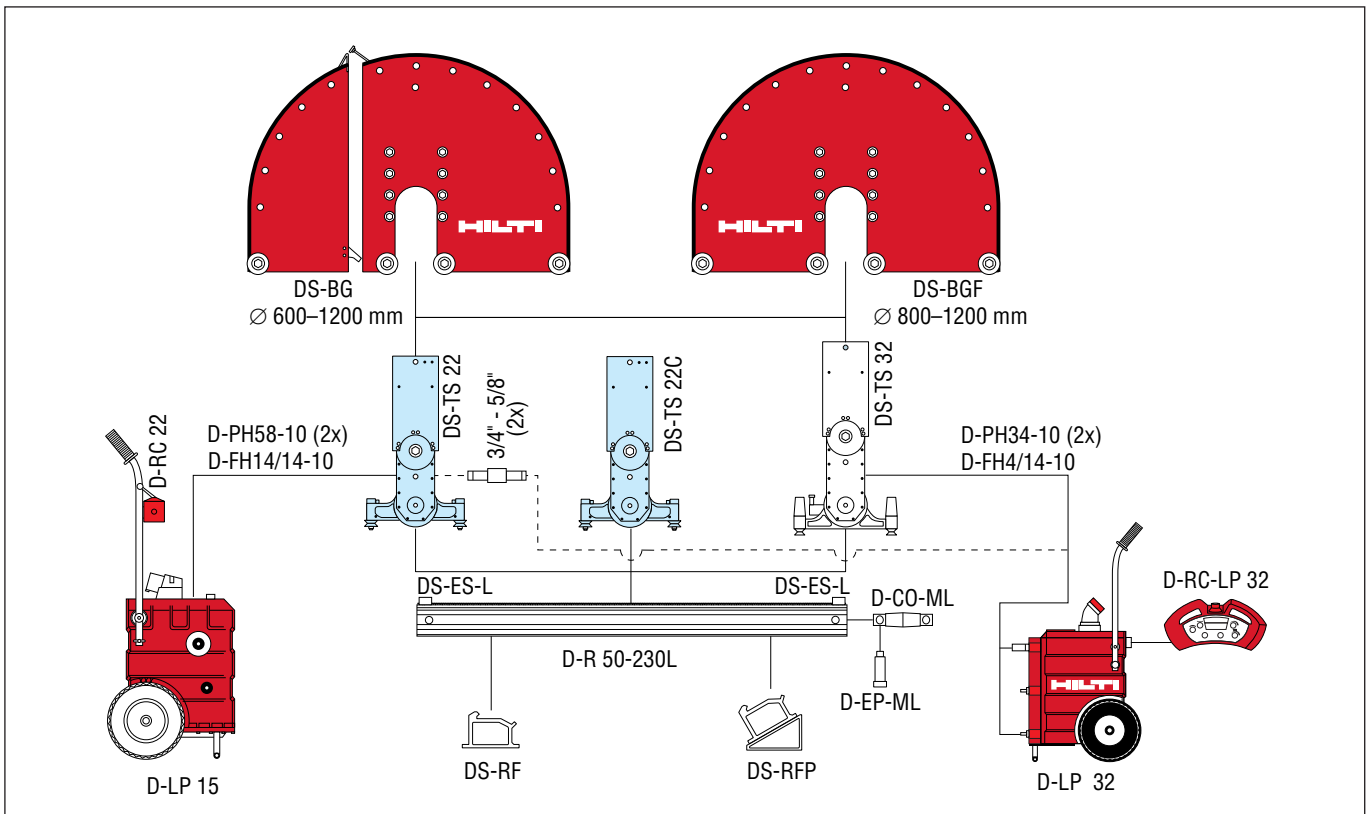

Main components and safety-relevant spare parts

Item no.	Designation	Use
000000	D-LP 15 hydraulic unit	
000000	D-TS 22 saw head	
310220	D-RC 22 remote control unit	Steuerung Sägekopf
284808	DS-R100-L rail	Saw guidance
284809	DS-R200-L rail	Saw guidance
284810	DS-R230-L rail	Saw guidance
207137	DS-CP-ML rail clamp	Fastening rails
284814	DS-RF-L rail support	Fastening rails
284816	DS-RFP-L rail support	Fastening rails for angled and stepped cuts
232241	D-CO-ML double taper	Extending rails
232244	D-EP-ML eccentric pin	Extending rails
371703	DS-ES-L end stop	Safety stop for saw head
221130	DS-PH 58-10 hydraulic hose	System hose
226393	DS-PH 58-1.6 hydraulic hose	System hose
221129	DS-FH 4/14-10 hydraulic hose set	System hose
221131	D-WH1 water hose	Water supply

Item no.	Designation	Use
238000	DS-BG65 blade guard	Blade guard for blades up to 650 mm dia.
238002	DS-BG80 center section	Blade guard for 600 to 900 mm dia. saw blades *
238003	DS-BG80 side section	Blade guard for 600 to 900 mm dia. saw blades
238004	DS-BG120 center section	Blade guard for 1000 to 1200 mm dia. saw blades *
238005	DS-BG120 side section	Blade guard for 1000 to 1200 mm dia. saw blades
238006	DS-BGF80 center section	Blade guard for 600 to 900 mm dia. saw blades for flush cutting *
238007	DS-BGF80 side section	Blade guard for 600 to 900 mm dia. saw blades for flush cutting
238008	DS-BGF120 center section	Blade guard for 1000 to 1200 mm dia. saw blades for flush cutting *
238009	DS-BGF120 side section	Blade guard for 1000 to 1200 mm dia. saw blades for flush cutting

* Only to be used with the corresponding side sections!

Item no.	Designation	Use
258436	DS-FCA-110 flush-cutting flange	Saw blade mounting flange for flush cutting
307188	DS-FCA-110FF auxiliary flange	Saw blade mounting flange for flush cutting

4. General description and technical data D-LP15/DS-TS22

The D-LP 15 / DS-TS 22 wall saw system is a high performance system for use with saw blades of up to 1200 mm dia. It is capable of cutting to a depth of 53 cm. The very compact DS-TS 22 / DS-TS 22 saw is equipped with a quick, easy cam-action roller mounting system, 360° pivoting sawing arm with built-in motor and 2-speed gear box that makes changing gear very simple. The saw blade mount employs a single screw and the drive spindle incorporates a central blade cooling system. Power to the motor and system control is hydraulic, making use of a semi-automatic controllable advance system which operates independently of the material being cut (once set, regulation is automatic). In conjunction with the very rigid and symmetrical D-R..L rail system, precise cuts and outstanding cutting performance can be achieved in all kinds of applications. Thanks to its oil-cooled electric motor, the D-LP 15 hydraulic unit is very compact. The DS-TS 22 saw incorporates a pressure relief valve and can therefore be powered by a number of different, specified hydraulic units. The D-LP 15, the standard hydraulic unit for use with this system, has a nominal power of 15 kW at 32 amps. It is also suitable for use with 16 amp mains supplies. This saw system is extremely convenient, can be assembled and operated quickly and easily by one man and provides optimal cutting performance at all times

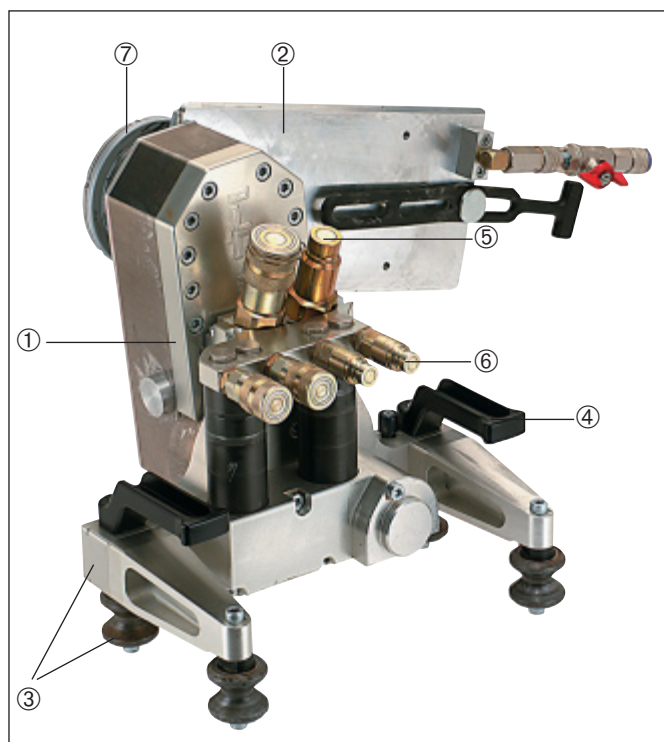

DS-TS 22

- ① Saw arm with built-in motor and 2-speed gearing
- ② Blade guard
(follows movement of the saw arm)
- ③ Carriage with wear-resistant steel rollers
- ④ Grip with cam-action roller
- ⑤ 5/8" coupling for pressure hose
- ⑥ 1/4" coupling for control hose
- ⑦ Saw blade mounting flange with single M12×25 screw

Technical data for the DS-TS 22

Blade diameter range	600–1200 mm
1st gear	800–1200 mm
2nd gear:	600– 800 mm
Cutting performance in moderately abrasive reinforced concrete using Hilti blades (guide):	approx. 2 m ² /h
Weight DS-TS 22:	27 kg
Hilti motor:	30 cm ³
Max. oil flow rate:	45 l/min
Max. operating press.:	190 bar
Hydraulic couplings	
Pressure hoses (PH):	5/8" (Holmbury type 4)
Control hoses (FH):	1/4" (Holmbury type 2)
TS 22 operation:	D-RC 22 remote control

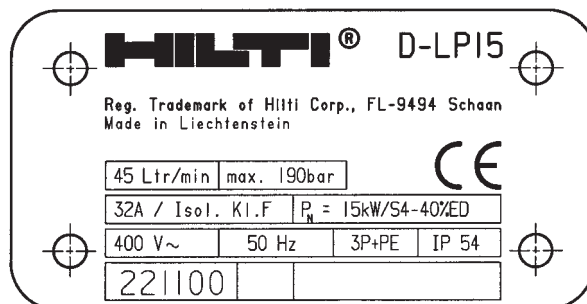
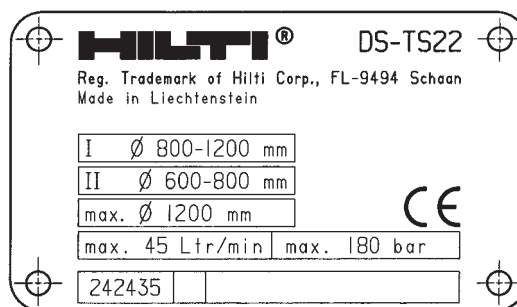

5. Spindle speeds, gear selection, rules of thumb, sawing procedure, saw blades

5.1 Optimum cutting speed (blade peripheral speed): As a guide, most saw blade manufacturers, including Hilti, recommend a speed of approx. 40 m/sec. Depending on the situation (concrete quality, aggregates, reinforcement etc.) speeds of 30–50 m/sec. may be used.

5.2 Recommended speed and gear (r.p.m. under load) – guide values

High (2nd) gear – 1200 r.p.m.

DS-B saw blade dia. (mm)	600	700	750	800
Peripheral speed m/s	38	43	47	50

Low (1st) gear – 700 r.p.m.

DS-B saw blade dia. (mm)	800	900	1000	1200
Peripheral speed m/s	30	33	36	44

5.3 Changing gear with the DS-TS 22

Use the hex. wrench with T-grip to select the gear before mounting the saw blade. Insert the wrench in the bore in the blade mounting flange and turn it in the direction indicated by the marks engraved on the saw head.

- High (2nd) gear = turn the wrench to the left as far as it will go
- Low (1st) gear = turn the wrench to the right as far as it will go.
- If an intermediate position is selected by mistake, the spindle will NOT rotate.
- The gear change mechanism should be kept clean and lubricated with Hilti spray at weekly intervals.

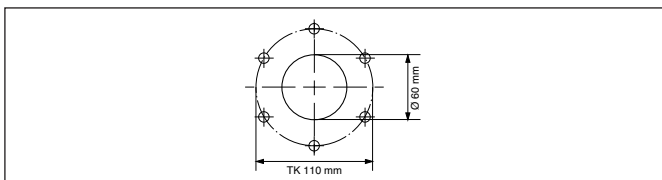
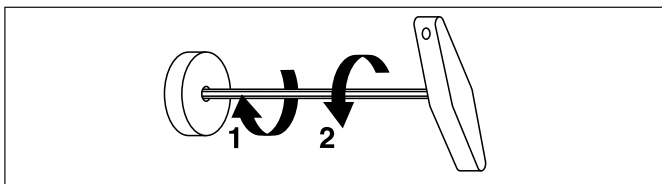
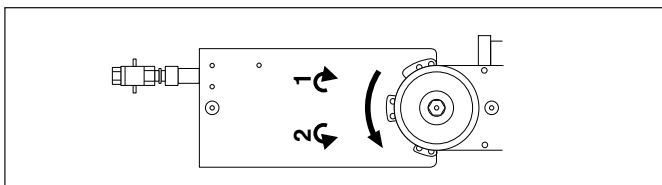

5.4 Rule of thumb for peripheral speed / cutting speed

- Reduce the peripheral speed when hard aggregates are encountered (silex, flint etc.).
- The peripheral speed can be increased when the concrete cuts easily.
- Use the normal, recommended peripheral speed when the steel reinforcement content is high.

5.5 The sawing procedure

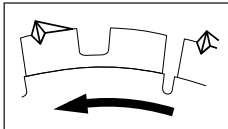
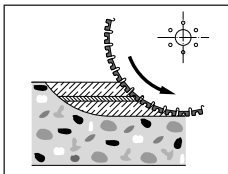
- Always mount the saw blade in the correct direction of rotation. The direction of rotation of the motor is engraved on the saw head. The cutting edge of the diamond grit must face the direction of rotation. 
- Use a small saw blade (600 mm dia.) to cut an approx. 5 cm deep guide kerf (in London flint, maximum 2 cm) at approx. 70% power output (approx. 100 bar operating pressure).
- Depending on conditions, subsequent cuts can be made to a depth of approx. 10–15 cm at full power, i.e. at 32 amps and an operating pressure of 160–180 bar (guide value).
- When reinforcing bars are cut lengthways, or when a large area of steel must be cut, position the saw blade so that concrete above and below the steel is also cut. This prevents polishing of the segments.
- Do not attempt to work with a blade if its segments have become polished. A blade with polished segments can be resharpened by making a shallow cut (2–3 cm) in unreinforced concrete or in an abrasive material using little water. Alternatively, the segments can be resharpened by making a dry cut in the Hilti sharpening plate. 

5.6 Saw blades – the Hilti DS-B saw blade programme

- The quality of the saw blade and selection of the correct type of blade is decisive. The Hilti DS-B blades types CS-M and CM-M have been designed for use with the DS-TS 22. They achieve optimum cutting performance while reducing the load on the saw system to a minimum.

6. Preparing the workplace and the saw system

6.1 The warnings and safety precautions listed in sections 1 and 2 must be observed.

6.2 Power requirements and cooling water

- Ensure that the electric supply has a fuse rating of 32 amps (minimum 16 amps) and that the earth / ground connection is functional (this is the responsibility of the site manager).
- Use an electric extension cable with standard Euro plug as per EN CEE 32. Select the cable cross section according to the load it is to carry (amps) and the cable length. Please refer to the following table:

Cross sectional area of individual cable cores (F)

Current Amps (A)	Hydraulic unit	F mm ² 2.5	F mm ² 4	F mm ² 6	F mm ² 10	F mm ² 16
16	LP 15/400V	49	78	117	195	m*
20	LP 15/400V	39	63	94	156	250
32	LP 15/400V	24	39	59	98	156

* maximum cable length in meters

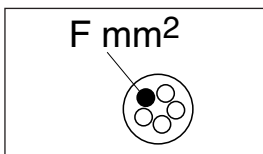

Electric cable

CEE 32 plug (male) on the D-LP 15 400 V – pin assignment

- PE = earth / ground
- N = neutral (not used)
- L1 = phase
- L2 = phase
- L3 = phase

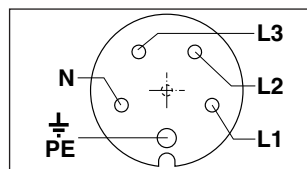

- Ensure that the water supply has a pressure of 4–6 bar. The normal cooling water flow rate is 10 l/min. For technical reasons, the flow rate must be not less than 5 l/min.
- Make suitable arrangements for water removal, depending on the job and situation, e.g. water barriers, wet-type vacuum cleaner, cover with plastic sheets etc.

6.3 Clarify the situation and secure the workplace

- Obtain approval from the site engineer or site management before beginning sawing. Find out whether overcutting at corners is permitted. If not, the corresponding corner holes must be planned and drilled first.

- Check that the area is cordoned off, that supports are in place and warnings to third parties are displayed.

6.4 Planning the cutting sequence and marking the cuts and fastening points

- The parts to be cut out are usually marked by the client. A rational cutting sequence can be followed when the rail supports are well positioned.
- If necessary, adjust the maximum size and weight of the concrete blocks to the prevailing conditions by making dividing cuts, e.g. in accordance with the work order, the means of handling the blocks, the capacity of the crane or the maximum floor loading capacity.

6.5 The cutting sequence

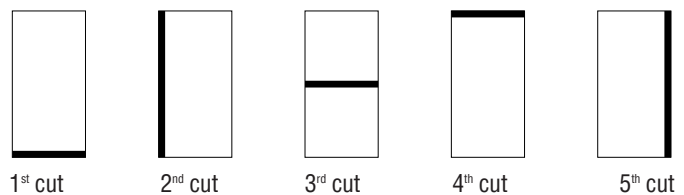

Steel wedges can be used as necessary to secure the cut-out concrete blocks.

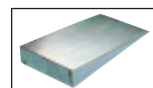

Designation: Steel wedge

7. Setting up the saw system for various applications

7.1 Fastening to the base material

- The saw system can only be used efficiently and safely when it is anchored rigidly and securely to the base material. We recommend the use of Hilti drilling machines and anchor systems.
- The rail supports and angular cutting plates must be fastened using anchors suitable for the base material.

WARNING

Use an anchor suitable for the material on which you are working and observe the anchor manufacturer's instructions.

NOTE

Hilti M12 metal expansion anchors are usually suitable for fastening diamond core drilling equipment to uncracked concrete. Under certain conditions it may be necessary to use an alternative fastening method. Please contact Hilti Technical Service if you have any questions about secure fastening.

- For example, when using the Hilti HKD M12 metal expansion anchor, a minimum edge distance of 18 cm must be observed. Generally speaking, the concrete dust should be blown out of the hole and the anchors should be set > 5 mm below the concrete surface.
- On masonry etc., for example, Hilti HIT adhesive anchors or through rods may be used.
- On extremely uneven surfaces, suitable shims or packing pieces must be positioned beneath the rail supports and / or the rail support adjustment screws adjusted accordingly.
- The most frequently used anchor on reinforced concrete:

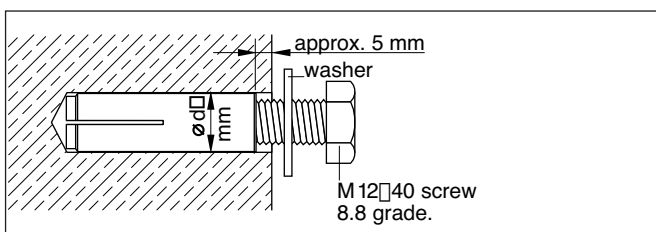

HKD-D M12x50, d 16
HKD-E M12x50, d 15

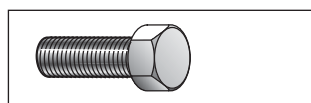

The use of galvanized screws is recommended.

7.2 Positioning the rail supports for standard cuts

DS-TS 22 main dimensions

Dimensions before beginning cut (mm)

Example: sawing out a door opening

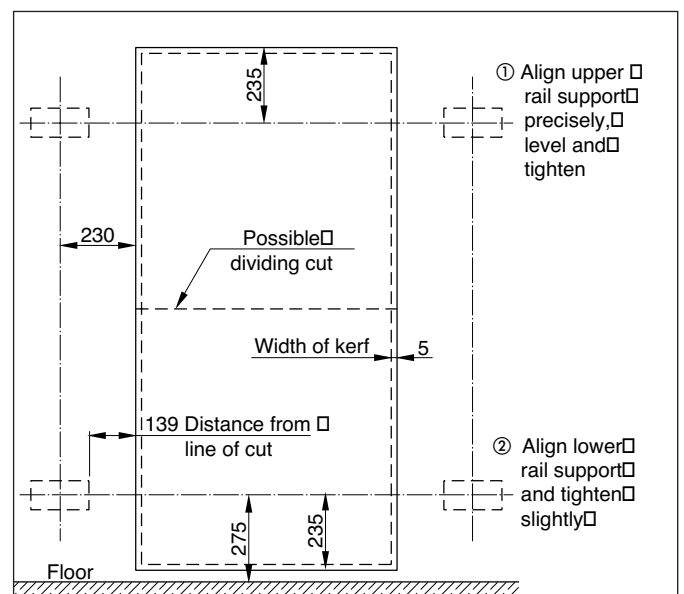
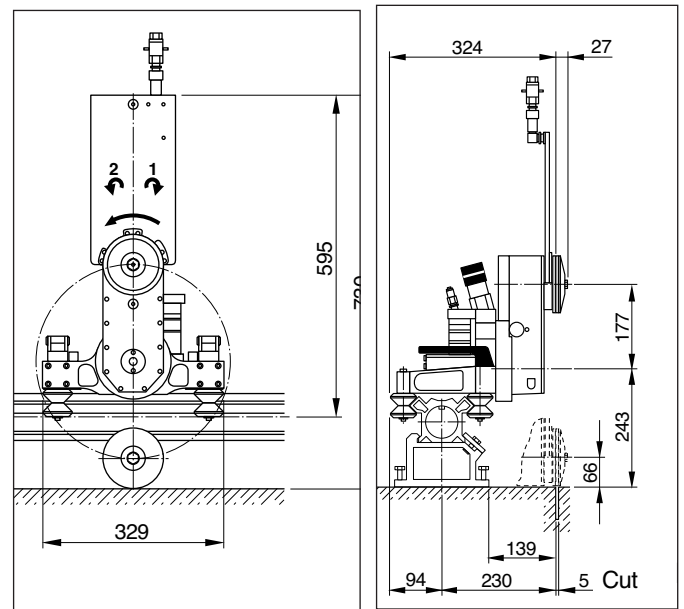

7. Setting up the saw system for various applications

7.3 Mounting the D-R..L rail, clamping piece and rail extension

- D-R..L rails are available in 50, 100, 150, 200 and 230 cm lengths.
- Use the D-CP-M/L clamping piece when the rail is mounted vertically. Attach the clamping piece to the D-R..L rail and hook it into the upper, previously aligned and levelled DS-RF rail support.
- Position the lower end of the rail in the lower rail support (not yet fully tightened), slide up the clamping plate and tighten the M12 screw. Check the distance from the cutting line and alignment of the rail before fully tightening the screw.
- When mounting the rails, always position the rail support at right angles to the rail and then tighten all rail fastening screws securely.
- All Hilti D-R..L rails can be extended to form a rigid unit by making use of a tapered connector: D-CO-ML double taper, eccentric pin.
- The recommended distance between rail supports is approx. 1.5 m.
- When a double taper is not available for use, rails can be extended by mounting a rail support at the joint between two rails.
- D-R..L rails are also used as the column in the DD-750 HY hydraulic drilling system.

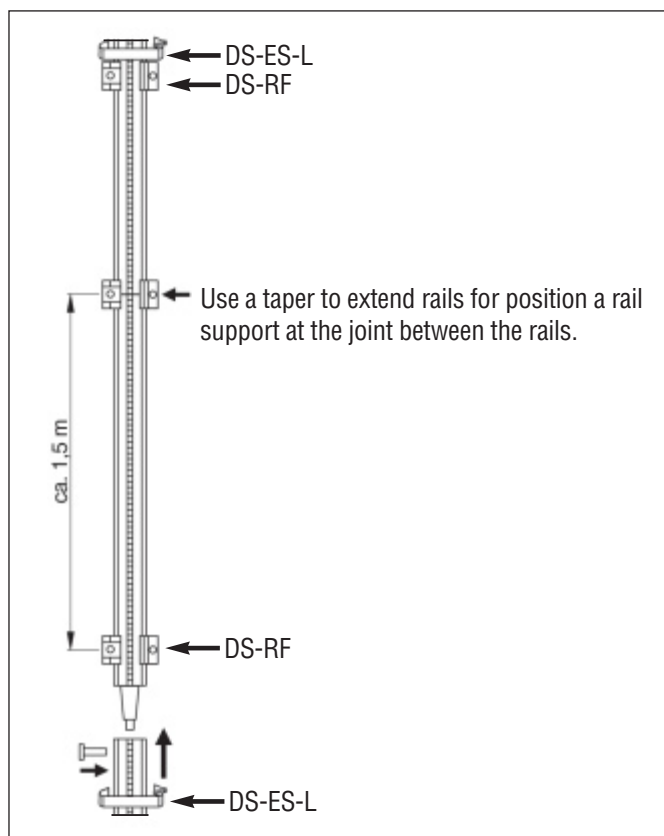

D-CO-ML
double taper



D-EP-ML
eccentric pin



D-CP-M
clamping piece



DS-ES-L
end stop

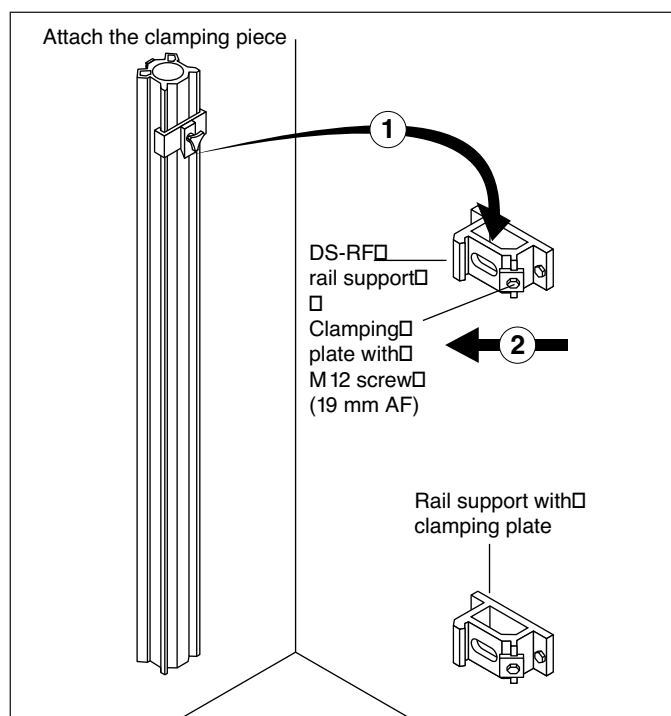

7. Setting up the saw system for various applications

7.4 Mounting the DS-TS 22 saw head, hydraulic hoses and saw blade

- The saw arm should be in the starting position (vertically upwards). Press the black release buttons ③ with the thumbs and bring the grips ② into the open position by pivoting them towards the saw arm until they engage in position. The eccentric rollers ④ on the saw arm side are now in the open position.
- Position the saw head on the rail (rail already fastened securely), engage the carriage with the teeth on the rack and close the eccentric rollers by pressing the lockbuttons with the thumbs and pivoting the grips into the closed position.
- Connect the D-PH 58 hydraulic hose ⑤ (5/8" pressure hose for the motor) and the D-FH 4/14 hose set ⑥ (1/4" control hose) to the saw head.
- Bring the blade guard holder ⑦ into a suitable position on the saw arm. Use the hex. wrench (10 mm AF) to tighten the hex. screw in the centre of the saw arm securely before mounting the saw blade. The holder and the blade guard then remain in the desired position during the entire sawing procedure.

Mounting the saw blade

- Select the saw blade (diameter, type CS-M or CM-M) depending on the concrete, the job to be done and the cutting sequence using saw blades of different diameters.
- Select the correct gear (slow speed – 1st gear / fast speed – 2nd gear).
- Position the saw blade in the correct direction of rotation on the drive hub of the saw arm.
- Fit the special blade flange ⑧ and the special screw ⑨ M12×25 (10.9 grade).
- Rotate the blade slightly so that the countersunk holes for fastening the blade for flush cutting are positioned BESIDE the 6 water grooves.
- Use the ring wrench to tighten the special M12 screw securely.

7.5 Instructions for handling hydraulic hoses and hydraulic couplings

- Always clean the couplings with a cloth before connecting. Turn the securing ring on the coupling after the click is heard.
- To ensure reliable operation and extend the life of the entire system, it is important that all hydraulic couplings are cleaned daily.

- Do not leave hydraulic couplings lying in the dirt and do not knock them against concrete surfaces. Avoid dragging hydraulic hoses over sharp edges.
- After transporting all modules to the workplace, the hydraulic unit should be positioned correctly and the hydraulic hoses connected to the unit immediately. In this way, no pressure can build up in the hoses even when directly exposed to the heat of the sun.
- If the hydraulic hoses cannot be connected, try to relieve pressure in the system by operating all valves (controls). Alternatively, the D-PRT pressure release valve can be used to release the pressure. The small quantity of oil which escapes should be caught in a cloth.
- Before disconnecting couplings, first turn the locking sleeve until it engages in position with the ball.



D-PRT FH 1/4" pressure release valve



D-PRT PH 5/8" pressure release valve

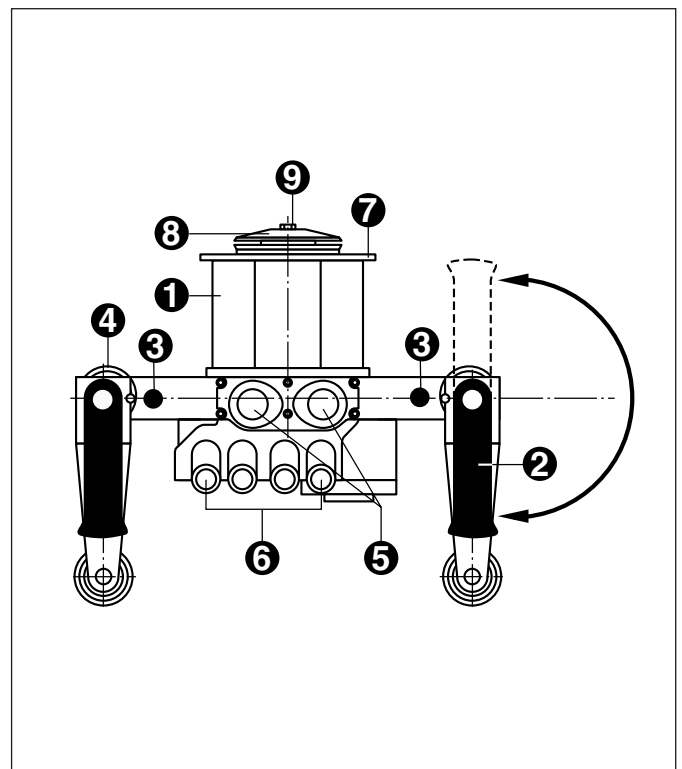

7. Setting up the saw system for various applications

7.6 Blade guard

- Always ensure that the DS-BG blade guard is in place when the saw is in operation.
- The blade guard is in two sections to permit cutting into corners.
- Thanks to its symmetrical design, the blade guard can simply be turned to permit cutting into a corner to the left or right (or upwards and downwards) without removing the blade from the kerf.
- Use the hex. wrench 10 mm AF to tighten the blade guard. The blade guard then always stays in the same position.
- Use the DS-BGF blade guard (open on one side) for flush cutting.



7.8 Flush cutting using the innovative DS-FCA-110 flush-cutting flange

- As for standard sawing applications, the blade can be fitted after the saw has been mounted on the rail. (Old method: The saw and the fitted saw blade had to be lifted together onto the rail and the saw blade guided into the kerf).
- The 2-piece DS-FCA-110 flush-cutting flange will permit more rapid progress and help prevent back injuries caused by lifting heavy loads.
- The Hilti saw system can be preassembled and positioned extremely precisely.
- The control system permits the saw arm to be pivoted effortlessly into position in the saw blade.
- Spindle speeds and the sawing procedure are as for standard applications.

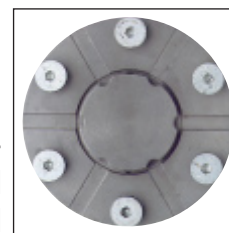

7.7 Using the DS-RFP angular cutting plate

- The angular cutting plate is used for sawing on stairs, in tunnels and for producing cuts at an angle of up to 45°.
- Align the equipment by using a protractor to measure the angle at the blade mounted on the saw.
- Due to the angle of the blade, cutting depth is reduced. The blade is also subjected to additional bending loads. Please refer to the following table for setting-up dimensions and cutting depths.

IMPORTANT: When making angular cuts, make a shallow guide cut and begin cutting gently!

Angle of cut	10°	20°	30°	40°	45°
∅	900	900	900	900	900
C	30	24	18	8	3
A	24	26	29	34	38

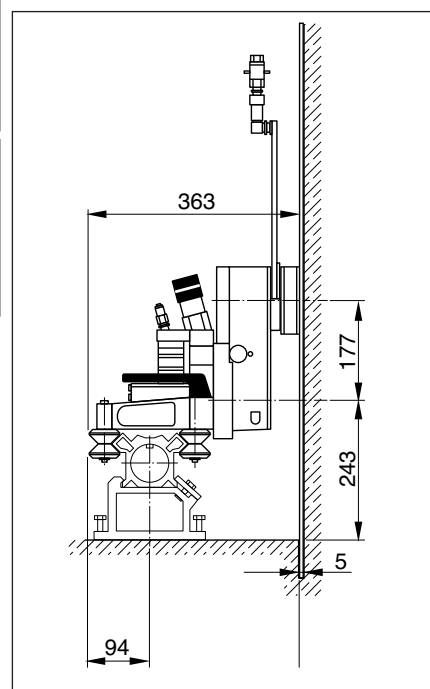
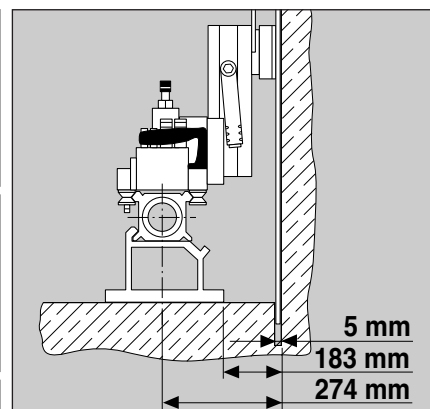
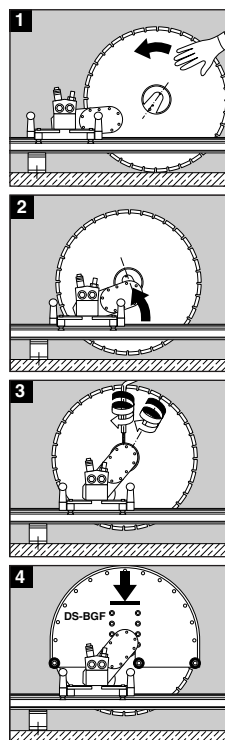
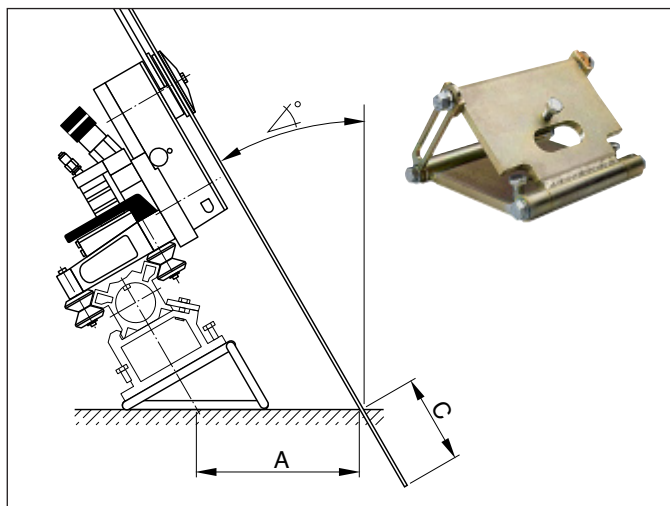

7. Setting up the saw system for various applications

7.9 Tool set for the D-LP 15/DS-TS 22/DD-750 HY

The items in the tool set are required for correct, safe operation of the wall saw system.

Ordering designation	Qty.	Use
LP 15-TS-HY tool set	1	D-LP 15/DS-TS 22/DD-750 HY
comprising:		Hydraulic sawing and coring
Hilti plastic toolbox with insert	1	Operator
Accessories, list of contents and their use	1	Operator
Folding rule, 2 m	1	Operator
STOF cleaning cloth	1	Operator
Flat brush	1	Operator
Hilti spray	1	Operator
Hilti grease dispenser	1	Operator
Ear protectors	1	Operator
BB blow out pump	1	① Blowing out anchor holes
Spirit level	1	Assembling rails
Open-end / ring wrench, 19 mm	1	Assembling rails
Open-end / ring wrench, 13/18 mm	1	Assembling rails/Eccentric rollers
Screwdriver, 6 mm	1	Assembly
Hammer 1½ kg	1	Setting anchors
Socket, 19 mm AF	1	Assembling rails
Extension, ½" square drive	1	Assembling rails
Ratchet, ½" square drive	1	Assembling rails
D lever with ½" square drive	1	Assembling rails
D-CP-ML rail clamp	1	② Mounting rails
Hex. screw, M 12×40/8.8	8	Fastening rail support
Hex. screw, M 12×70/8.8	8	Fastening rail support
Washer A13	8	Fastening rail support
DS-RF clamping piece	1	Spare part rail support
Washer, 12×18×1	3	Spare part rail support
Spring, 1×12×25	3	Spare part rail support
M 12 nut with collar	8	Angular cutting plate
D-EP-ML ½" eccentric pin	3	Rail extension
D-CO-ML taper	1	③ Rail extension
Rubber	2	Blade guard holder
Grip nut	1	Fastening blade guard
Hex. key, 4 mm	2	Covers
Hex. key, 10 mm	1	Fastening blade guard holder
DS hex. key with T-grip	1	Saw head gear change
Oil change sticker	1	D-LP 15 hydraulic unit
D-LP 15 plug contact	1	D-LP 15 spare part
T4A / 250 V fuse	10	D-LP 15 transformer spare fuse
D-PRT pressure release valve FH ¼"	1	④ Pressure release FH ¼"
D-PRT pressure release valve PH ⅝"	1	⑤ Pressure release PH ⅝"
D-steel wedge 130×70×20	6	⑥ Securing concrete block
Copper ring	5	Core bit extension
Special M 10 countersunk-head screw (set of 6)	1	Spare part, DS-FCA flange
Set of 3 seals	1	Spare part, DS-FCA flange
Special hex. screw, M 12×25/10.9	2	Spare part, mounting saw blade
Hose coupling, 15–24 mm	2	Attaching water hose

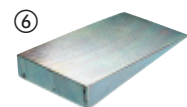

7. Setting up the saw system for various applications

Additional accessories for the D-LP 15/DS-TS 22/DD-750 HY

The following items are not included in the tool set:

Ordering designation	Qty.	Use
DS-ES-L end stop	2	⑦ End stop for L rail
Water valve Y-piece	1	⑧ Water supply
Water valve	1	⑨ Water supply
Water connector for saw head	1	Spare part for saw head
DD 750-HY water hose	1	⑩ Spare part for DD-750 HY
Hydraulic coupling, FH 1/4" (female)	1	Spare part for FH 1/4"
Hydraulic coupling, FH 1/4" (male)	1	Spare part for FH 1/4"
Hydraulic coupling, PH 5/8" (female)	1	Spare part for PH 5/8"
Hydraulic coupling, PH 5/8" (male)	1	Spare part for PH 5/8"
HVLP 46 hydraulic oil (25 litres)	1	Hydraulic unit
Sharpening plate, 319 × 319 × 18 mm	1	Saw blades, core bids
CEE 32 A plug socket (female)	1	Power extension cable
Open-end wrench, 36 mm AF, DIN 894	1	Core bits / extension / fitting
Open-end wrench, 41/46 mm AF, DIN 895	1	Core bits / extension / fitting

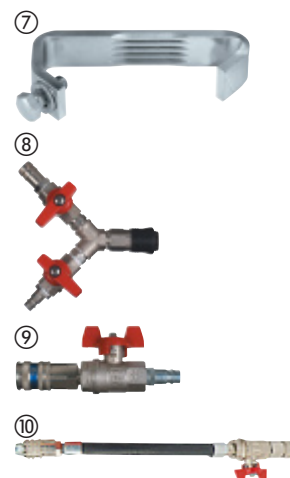

7.10 Using other hydraulic units to power the DS-TS 22 saw heads

- This is permitted only when the hydraulic unit fulfils the following conditions:
 - Maximum oil flow rate 45 l/min.
 - Maximum operating pressure 190 bar.
 - Modifications to the DS-TS 22 hydraulic couplings are NOT permitted. In particular, the directions of advance and return (marked with an arrow) must be observed.
- The user carries the responsibility for ensuring that the control system employed functions correctly. It is of advantage to make use of the D-RC 22 with the DS-TS 22.
- Damage to the DS-TS 22 resulting from use of a hydraulic unit other than the D-LP 15 to power the system is not covered by the warranty provided by the Hilti corporation.
- If the D-LP 32(30) hydraulic unit is used, power setting 5 should not be exceeded, i.e. max. oil flow rate 45 l/min.

7.11 Connecting and operating the DS-TS 22 with the D-RC22

- The DS-TS 22 must be controlled by the D-RC 22 remote control unit.
- The D-RC 22 remote control unit can be mounted conveniently on the hydraulic unit.
- If desired, the D-RC 22 may be mounted on a separate stand.

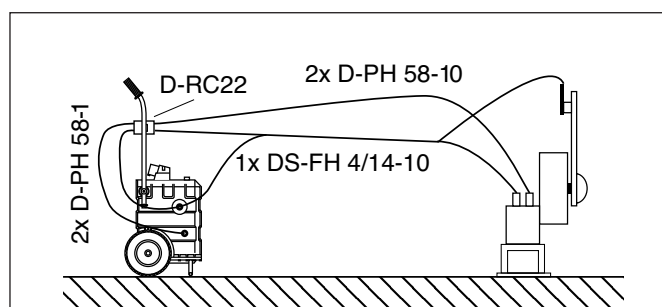

7. Setting up the saw system for various applications

7.13 Hilti DS-TS saw heads, saw blade diameters and cutting depths, remaining distances for the DS-TS 22 and DS-TS 32C saw heads

Cutting depth T (cm)

Saw blade diameter	DS-TS 22 2 gears	T (cm)	DS-TS 32 1 gear	T (cm)
600 mm	●	23	○	
700 mm	●	28	○	
750 mm	●	31	○	
800 mm	●*	33	●	33
900 mm	●	38	●*	38
1000 mm	●	43	●	43
1200 mm	●	53	●	53
1500 mm			●	68
1600 mm			●	73

* Largest initial diameter, ● main application, ○ possible application

TS 22 remaining distances

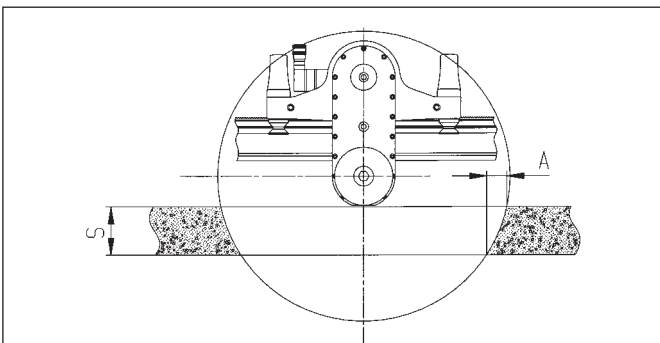

TS 22 remaining distance A (cm)

S (cm)	A 600 mm	700 mm	800 mm	900 mm	1000 mm	1200 mm
15	8	7	6	5	4	3
20	15	11	9	8	7	6
25		19	15	12	11	8
30			23	18	15	12
35				27	21	16
40					31	22
50						40

TS 22 remaining distances

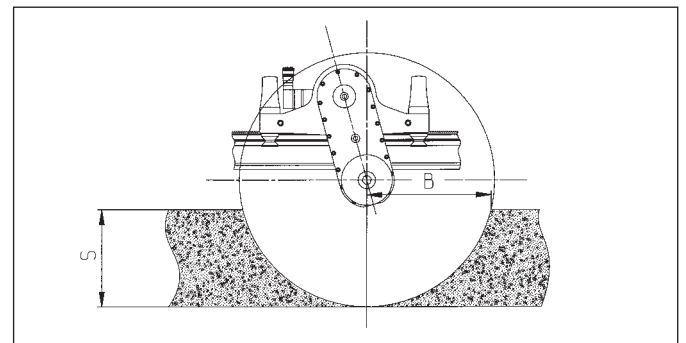

TS 22 remaining distance B (cm)

S (cm)	B 600 mm	700 mm	800 mm	900 mm	1000 mm	1200 mm
15	26	29	31	34	36	40
20	28	32	35	37	40	45
25		34	37	40	43	49
30			39	42	46	52
35				44	48	54
40					49	57
50						59

8. D-LP15 hydraulic unit – setting up operation, care and maintenance

8.1 Instructions for maintenance of the hydraulic units

- Check the oil level at weekly intervals and, if necessary, top up with hydraulic oil, type HVLP 46.
- The oil should be changed for the first time 6 months after the unit is put into service. Thereafter, change the oil every 12 months and apply the Hilti maintenance sticker. The D-LP 15 has an oil capacity of 20 litres.
- If power output drops when using a hydraulic unit or of the unit fails completely, it can be checked on the spot by a Hilti specialist.
- If the D-LP 15 makes an unusual noise when running, it may be that the oil level is too low or the unit has not reached operating temperature (too cold).
- Operation in winter or at low temperatures: The hydraulic unit should be allowed to run for a few min-

utes until warm (with water running) before a load is applied. The hydraulic hoses should be warm to the touch.

- Do not run the hydraulic unit without cooling water. Always keep the water running when operating at temperatures below 0! Disconnect the water supply hose from the unit when the work is finished - the unit then drains automatically. **Use only couplings of the free-flow type (without automatic valve)** for the water supply to the hydraulic unit!
- **Note:** If the voltage of one of the three phases is too low, the hydraulic unit will NOT start! Always check the mains supply first! The fuses should also be checked if the unit does not start. They are located under the cover. Please refer to section 10 for fault finding tips.

D-LP15 hydraulic unit

- ① 3-phase 400 V mains supply (380 V, 415V) with appropriate fuse rating: The switch electronics set the correct direction of rotation automatically. Standard plug as per EN CEE 32
- ② The unit employs a star/delta type switch (Y- Δ). Starting up takes only a few sec. (max. 5 sec.).
- ③ Use an extension cable of adequate cross-sectional area. The unit will not start if the voltage supplied is too low or if one of the phases is too weak. See section 6.2.
- ④ The water supply is always connected to the lower coupling on the hydraulic unit. Water pressure should be 4–6 bar, with a flow rate of 10 l/min. (at least 5 l/min.).
- ⑤ Coupling for the water supply to the saw head.
- ⑥ Dipstick for measuring the D-LP 15 oil level.
- ⑦ Keep the hydraulic couplings clean. When connecting the hoses, turn the securing ring after the coupling engages with an audible “click”.
- ⑧ Safety plugs are fitted. Switch on the unit only after everything has been connected and all operating levers are in the “O” (off) position.
- ⑨ DS-SB1 remote on/off switch for use with the DS-TS 22C or DS-TS 20 saw heads.
 - Disconnect the hoses from the water supply couplings ④ and ⑤ when the work is finished. The water then drains from the hydraulic unit (oil cooler) automatically.
 - If a generator is used to provide power, it must have an output of at least 30 kVA. **IMPORTANT:** The generator must be earthed/grounded.
 - The hydraulic unit must stand horizontally when in operation.
 - During transport, the hydraulic unit must be secured to prevent it from moving.
 - Lifting by crane: Use the transverse bar between the hand grips as the lifting point.
- ⑩ Wheels with puncture-proof tyres
- ⑪ Handle bar locking screw
- ⑫ Folding transport handle bar

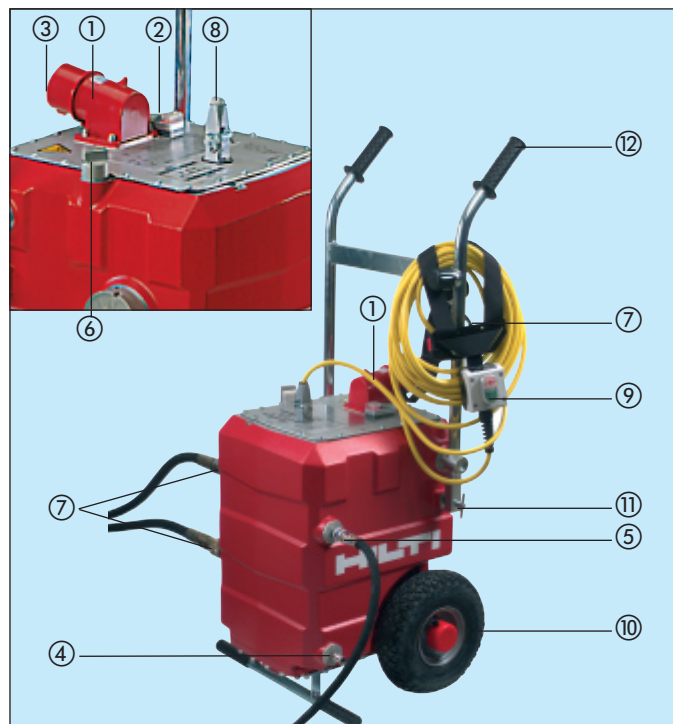

D-LP15 technical data

Rated power input at 32 A:	22 kW
Nominal power output:	15 kW
Fuse rating, min.:	16 A
Fuse rating, max.:	32 A
Rated voltage:	400 V / ~ 50 Hz, 3 P + PE
Ground fault circuit breaker (PRCD):	30 mA, in mains supply from site
Max. operating pressure:	190 bar
Oil flow rate:	45 l/min.
Weight:	approx. 113 kg
Hydraulic remote control:	D-RC 22
Electric remote ON/OFF:	DS-SB1
Protection class:	IP54

9. Setting up, checking and operating the saw system

9.1 Points to check before beginning sawing

- The rail supports and rails must be aligned and fastened correctly (all screws fastened securely).
- The saw head must be mounted without play, the eccentric rollers engaged and the correct gears selected.
- The hydraulic hoses and water hoses must be laid out, connected correctly and the locking sleeves engaged.
- A suitable saw blade must be mounted in the correct direction of rotation, the mounting screws tightened firmly and the blade guard mounted and secured.
- The electricity and water supplies must be ready for use, the operating buttons and levers set to the “0” (off) position and the appropriate safety measures implemented at the workplace.

9.2 Operation of the D-LP 15 / DS-TS 22 saw system using the D-RC 22

- The D-RC 22 unit is used as a separate remote control unit for the DS-TS 22:

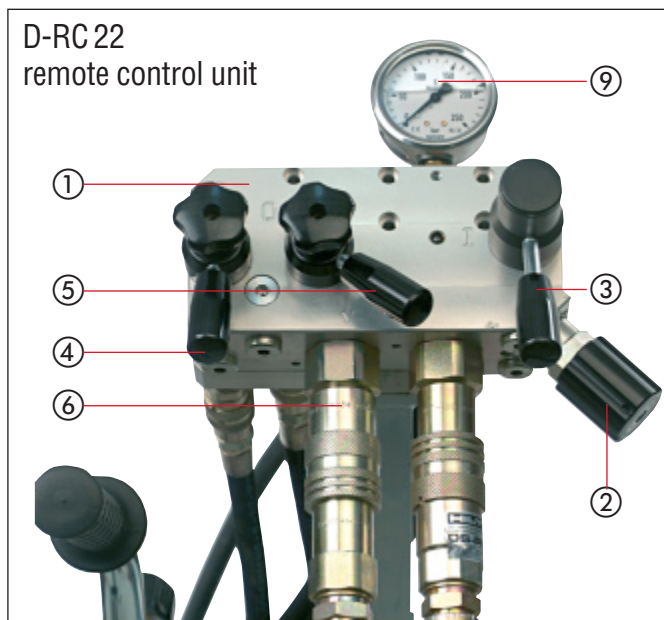

- ① D-RC22 control unit housing
- ② Power regulation knob
- ③ Lockable lever I/O = on/off, saw blade drive motor, main circuit
- ④ Plunge direction – knob controls plunge speed
- ⑤ Advance direction – knob controls advance speed
- ⑥ Couplings for PH 58 hydraulic hose from hydraulic unit
- ⑦ Couplings for PH 58 hydraulic hoses to saw head
- ⑧ Couplings for FH 4/14 control hoses to saw head
- ⑨ Pressure gauge, indicates pressure in bar to the drive motor
- ⑩ Clamp for mounting the D-RC 22 control unit on the D-LP 15

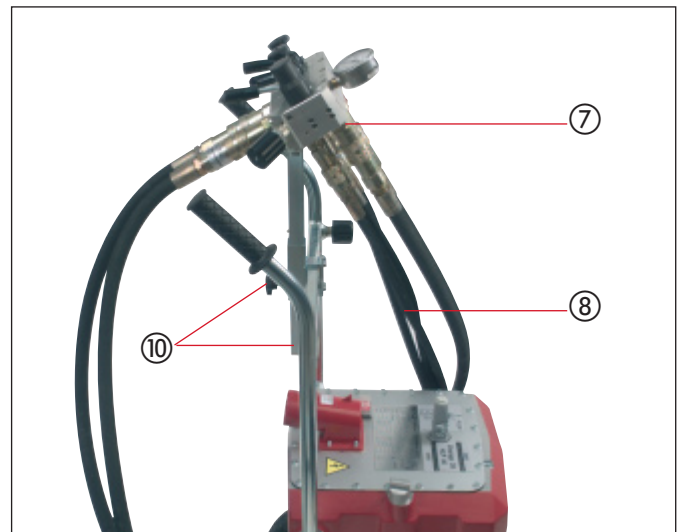

9.3 The Hilti saw system with semi-automatic advance control

- Adjust to the optimum/maximum advance speed during the first full cut at the optimum cutting depth and a hydraulic pressure of 160–180 bar. Make this adjustment when the saw is cutting in a section of the concrete which you consider to represent “normal” conditions. The adjustment should not be made, for example, when cutting a rebar lengthways or in a similar situation.

9.4 Important information on operating and controlling the system

- Once initially set, the system regulates itself, i.e. when heavy reinforcement is encountered, the saw head reduces the advance speed automatically and continues with a “stop and go” effect.
- The operator does not require to adjust the controls constantly. He can supervise the sawing procedure or, for example, mount the rail for the next cut.
- Advantages: Inexperienced operators can begin sawing productively after only a short time and experienced operators can achieve extremely high efficiency.
- The guide cut should always be made to minimal depth and with the saw arm in the “trailing” position.
- Do not make sudden adjustments. Give the system time to react to the adjustments.
- Working with the saw system connected to mains supplies of various fuse ratings:
- When connected to a mains supply with a fuse rating of 32 A, the system provides maximum power when the power adjustment knob ② is turned back

9. Setting up, checking and operating the saw system

to approx. the $\frac{1}{4}$ position. Do not close it completely, otherwise automatic control will no longer function.

- With a fuse rating of 16 A, the system can be operated at correspondingly lower power with the power regulation valve opened by approx. 1 (one) complete turn.
- If the blade sticks or stalls:
This happens from time to time. The safety system is activated immediately (the pressure limiting valve on the DS-TS 22 and the pressure release valve on the D-LP 15 are set to 190 bar). This situation presents no risk to the operator or the saw system. The operator should react by reversing the direction of advance. The saw blade then usually begins to rotate again. If not, the arm must be pivoted to lift the blade out of the kerf. These steps should be taken without delay. The blade drive motor should be switched off if it takes longer than 1–2 minutes to free a sticking/ stalled blade.

9.5 Starting the saw system and beginning the sawing procedure

- All operating levers should be set to the 0 = OFF position and the direction control levers should be in the neutral position.
- Close the power adjustment knob ② by turning it fully to the right. Open it again by turning it a $\frac{1}{2}$ turn to the left. This is then the starting position for making the guide cut and for beginning sawing.
- Switch on the water supply.
- Switch on the hydraulic unit at the green button (I) and listen to ensure that the electric motor switches from star to delta (Y- \emptyset).
- Quickly move the lockable lever ③ for the blade drive motor from 0 (OFF) to the I (ON) position.
- Move the plunge control lever ④ in the appropriate direction as far as it will go. Adjust the plunge speed regulating knob. Maximum speed \cong knob opened fully 1 turn. After reaching the correct depth, adjust the knob to 0 (close) and move the direction control lever to the neutral position.
- Set the advance lever ⑤ as far as it will go in the appropriate direction. Adjust the advance speed knob. Maximum speed \cong knob opened fully 1 turn. Leave it set at the optimum advance setting. The saw will cut continuously.
- Now close the power regulating knob ② slowly ($\frac{1}{4}$ turn to the right) in order to obtain maximum pow-

er. Listen and observe how the saw performs and keep your eye on the pressure gauge.

- In practice, once the operator has found and set the optimum power setting, he will leave control ② at this position and only make further adjustments when considerable variations in the material being cut are encountered.
- After a good guide cut has been made, subsequent cuts can be made with the saw arm in the leading or trailing position, as required.
- When the concrete has been cut through, lift the blade out of the kerf while it is still rotating and switch off the motor.
- Various operations require use of the advance movement or saw arm pivot movement without the blade motor running. This can be achieved by opening the motor control lever only slightly, without actually causing the blade motor to rotate. Controls ④ and ⑤ can then be used as described above.
- At the end of the cut, bring all the levers and buttons into the 0 position (switch off the blade motor slowly) and switch off the hydraulic unit.



After finishing the cut (if using the D-LP15/DS-TS22) switch OFF at the on/off (I-0) switch on the hydraulic power unit.

- The system should be cleaned initially at the workplace before it is dismantled.

10. Disassembly and fault finding

10.1 Disassembling the saw system

- Secure the block of concrete you have cut. Use steel wedges when necessary.
- Clean the equipment by spraying with water. Dry the parts with a cloth.
- Disassemble the blade guard, blade and other modules in the reverse order.
- Secure the block of concrete or carefully withdraw it from the hole and make arrangements for its transport.
- Cordon off the opening so that it presents no hazard to third parties.



10.2 Finding and eliminating faults in the D-LP 15 / DS-TS 22 saw system.

The operator will receive instruction from the Hilti specialist

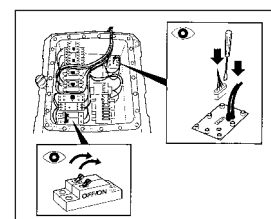
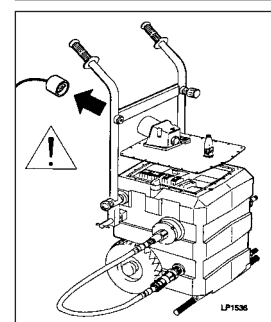
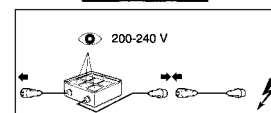
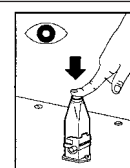
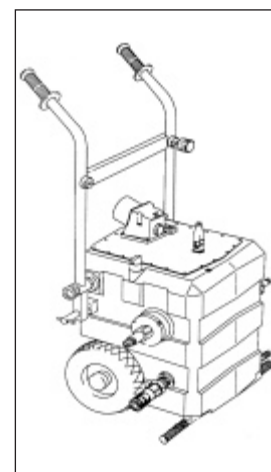
Check	Problem	Possible cause	Solution / action required
1	LP 15 hydraulic unit does not start	Plug contact is missing or defective	<ul style="list-style-type: none"> – Fit plug contact – Replace (tool set) – Jumper between 1–2 if necessary
2	LP 15 hydraulic unit does not start	Mains supply fault <ul style="list-style-type: none"> – Loose contact in plug – Circuit breaker OFF or defective 	<ul style="list-style-type: none"> – Check extension cable and plug, eliminate fault – Check circuit breaker / ON – Fit slow-acting fuse
3	LP 15 hydraulic unit does not start	Voltage of one of the 3 phases drops too much, undervoltage	<ul style="list-style-type: none"> – All 3 phases should supply approx. 230 V – Check 3 phases, use Hilti electrobox – Switch off other power consumers on the same line – Consult site electrician
4	LP 15 hydraulic unit does not start	– DS-SB1 remote on/off switch, item no. 221132/4, is connected with defective cable	<ul style="list-style-type: none"> – Check and replace if necessary – Insert plug contact 221659/6 – Jumper between 1–2 if necessary
5	LP 15 hydraulic unit does not start	Internal fuses for the 24 volt control circuit in the unit have been activated by a fault in the mains supply	<ul style="list-style-type: none"> – Disconnect extension cable from hydraulic unit plug – Use 4 mm hex. wrench to open cover of LP 15 electrobox
5.1		1 or 2 toggle switches (control circuit breakers) OFF	– Switch to “I” ON
5.2		Transformer fuse blown	– Insert new T4A fuse (in unit / toolbox)
5.3	Glass cartridge-type fuse blown	Fault in mains supply	– Fuse type: glass cartridge fuse 5x20 mm, DIN 41662, Type 4.0 A slow
5.4		Loose plug contacts	– Plug in
5.5	LP 15 hydraulic unit starts with difficulty or does not start	Automatic switching from Y to delta takes place too quickly – possibly due to low mains power	– Set time switch to 5 sec. (max. 10 sec.), approx. 2–3 sec. is normal

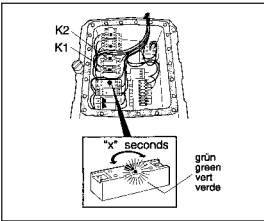
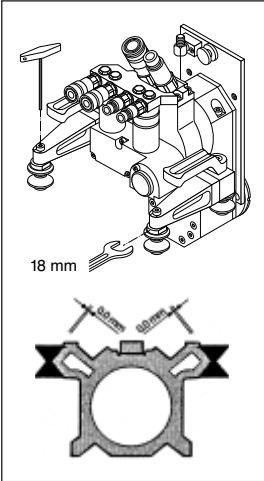

10. Disassembly and fault finding

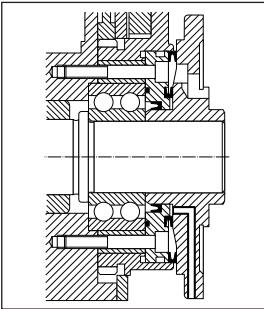
Check	Problem	Possible cause	Solution / action required	
6	Water in oil, risk of damage to electric motor	<ul style="list-style-type: none"> – Seals on the saw head worn or defective – Water cooler in hydraulic unit defective 	Check oil level when unit is open <ul style="list-style-type: none"> – Oil is clear = OK – Oil is milky white = water in oil (risk of damage: hydraulic unit must be serviced immediately!) 	
7	The mains supply cut-out is activated	<ul style="list-style-type: none"> – PH58 hydraulic hose not connected or not correctly connected – Fuse rating too low – Power regulation valve is set too high 	<ul style="list-style-type: none"> – Connect hydraulic hoses – Lock hydraulic couplings correctly – Check fuse rating – Open power regulation valve 	
8	Hydraulic unit becomes very hot, cannot be touched by hand	<ul style="list-style-type: none"> – Too little cooling water – Water supply connected to wrong connection 	<ul style="list-style-type: none"> – Water pressure 4–6 bar approx. 10 l/min., at least 5 l/min. – Connect water to lower connection 	
9	Blade wanders off line of cut	<ul style="list-style-type: none"> – Wrong sawing technique or saw blade – Rail not securely fastened – Play at the saw head 	<ul style="list-style-type: none"> – Refer to operating instructions for saw blades – Fasten correctly, see section 8 – Eccentric rollers – adjust play at saw head using T-grip wrench and 13/18 mm AF wrench 	
10	Water or oil leakage at the saw arm motor flange	<ul style="list-style-type: none"> – Defective water seal – Defective oil seal 	<ul style="list-style-type: none"> – Check at radial hole on blade flange – Have the saw head serviced 	

CAUTION

Disconnect the supply cord plug from the power outlet.

CAUTION

Keep the machine, especially its grip surfaces, clean and free from oil and grease. Do not use cleaning agents which contain silicone.

11.1 Cleaning the equipment

- We recommend that the most important parts of the saw system are cleaned quickly between each saw cut. Simply use the water hose to wash down the saw head, rails, blade guard and saw blades.



- All switches and controls must be set to the "off" or neutral positions and the power supply cable unplugged before beginning thorough daily cleaning.
- Immediately after finishing work each day, use the water hose and a brush to wash down the entire set of equipment thoroughly, paying particular attention to the parts mentioned above. Cleaning should be planned as a part of the working procedure. This will ensure that the equipment can be operated efficiently each day.

Cleaning with high-pressure or steam cleaning systems

If a cleaning system of this kind is used to clean the saw head, do not direct the jet into openings or at seals.

11.2 Maintenance of the D-LP 15 hydraulic unit

- Check the oil level of the hydraulic unit at weekly intervals. Top up if necessary with type HVLP 46 hydraulic oil.
- **Changing the oil and filter:** Change the hydraulic oil (type HVLP 46) and filter after approx. 200 operating hours or once a year. The service sticker on the cover of the hydraulic unit indicates when the next service is due.
- Should the unit seem to lack power, it can be checked on the spot by a Hilti specialist if necessary.
- Do NOT use a steam cleaning system or water jet to wash down the hydraulic unit.
- **Operation in winter or at low temperatures:** When cold, the hydraulic unit should be allowed to run for a few minutes, with water flowing, until it has warmed up.

- Do not operate the hydraulic unit without cooling water connected. Always keep the water running when operating at temperatures below zero. Disconnect the water supply to the hydraulic unit and the water system hose when work is finished. The hydraulic unit then drains itself automatically. **Use only water hose couplings of the free-flow type** for the water supply to the hydraulic unit.
- If an electric generator is used to power the D-LP 15 hydraulic unit, we recommend an output of at least 30 kVA. The generator must be earthed.

11.3 Maintenance of the DS-TS 22 saw head

- The saw head basically requires no maintenance. We recommend annual servicing.
- The hydraulic couplings should be cleaned daily and checked to ensure ease of operation.
- The guide rollers and cam-action rollers should be kept clean and lubricated with Hilti oil spray.
- Check occasionally to ensure there is no play between the carriage and the rail and adjust correctly if necessary.
- Use Hilti oil spray to protect and lubricate the gear change mechanism. Keep the mechanism clean and ensure that it operates smoothly.

11.4 Maintenance of the other saw system modules

- The D-R..L rails have a transparent anodised finish and can be washed very easily. The internal taper on the rails should be cleaned particularly carefully with a cloth and then lubricated with Hilti oil spray.
- The other modules such as the blade guard, rail supports, etc., basically require no maintenance. Nevertheless, we recommend immediate cleaning each time after use.
- The hydraulic hoses should be cleaned daily, paying particular attention to the couplings to ensure ease of operation.

11.5 Service and repair

- Malfunctions are unlikely when the equipment is kept clean and lubricated. Lack of cleaning and incorrect operation may lead to malfunctions.
- Additional parts (spare parts) are available from Hilti service when required and, under normal circumstances, can be fitted on site by the operator himself, by a Hilti specialist or Hilti repair mechanic.

12. Manufacturer's warranty – tools

Please contact your local Hilti representative if you have questions about the warranty conditions.

13. EU declaration of conformity (original)

13.1 EU declaration of conformity (original)

Description:	Hydraulic saw system
Serial numbers:	Up to 9999
Designation:	D-LP15/DS-TS2
Year of design D-LP15:	1992

We declare under our sole responsibility that this product complies with the following directives and standards: until 19th April 2016: 2004/108/EC, from 20th April 2016: 2014/30/EU, 2006/42/EC, 2011/65/EU, EN 60204-1, EN 12100.

The DS-TS 22C has been phased out of our product range and is excluded from this declaration.

Do not use this product in any way other than as directed by these operating instructions.

13.2 Noise and vibration

Typically the A-weighted noise levels of the product are:

Sound pressure level:	90 dB(A)
Sound power level:	103 dB(A)

Wear ear protection.

Hilti Corporation, Feldkircherstrasse 100, FL-9494 Schaan



Paolo Luccini
Head of BA Quality and Process Management
Business Area Electric Tools & Accessories



Johannes Wilfried Huber
Senior Vice President
Business Unit Diamond

06 / 2015

06 / 2015

Technical documentation filed at:
Hilti Entwicklungsgesellschaft mbH
Zulassung Elektrowerkzeuge
Hiltistrasse 6
86916 Kaufering
Deutschland



Hilti Corporation

LI-9494 Schaan

Tel.: +423/234 21 11

Fax: +423/234 29 65

www.hilti.com

